

Heizgerat Setzt™ with illuminated switch Installation Retrofit Universal Application

Important Information

Heizgerat Setzt is the premium division of **Heizgerat Setzt Germany**. The content of this installation manual may not be necessarily facts, just a lot of knowledge from experienced installers that install for a living. What may work for some may not work for others.

Heizgerat Setzt™ Seat Heaters are only to be installed by qualified professionals who have a technical background with working on automobiles. Always ensure that the cables/elements are not kinked or damaged as you install them in the car. Some of the work is only shown on the driver side of the car. Therefore you may proceed in exactly the same way on the passenger side of the car.

Subject to Technical Modifications.

Special tools maybe required

- A Hog Ring Pliers
- B Hollow Hole Punch
- C Multimeter
- D 12 Volt Electrical Tester With Light
- E Unibit Drill (capable of 20mm)
- F Long Bent Jaw Needle Nose Pliers
- G Hammer
- H Wire Cutter and Scissors

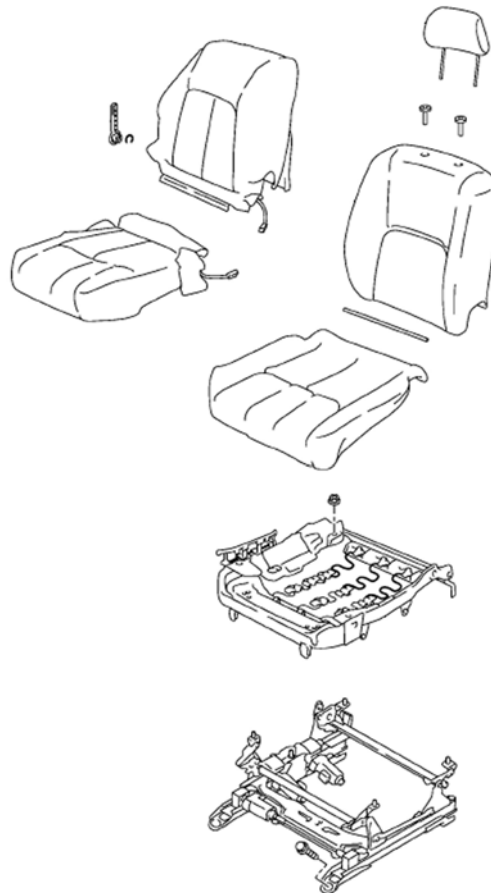

Special parts maybe required

- A Fusetap
- B Fusetap Connectors
- C Tap Connectors
- D Grounding screws
- E Insulated Battery Post Connectors

Figure 1 : Removal of the Seat Cushions

Table of Contents

Sections	Pages
1. Important Information.....	1
2. Table of Contents.....	2
3. Disclaimer.....	3
4. Package Contents.....	4
5. Removing Car Seats.....	5
6. Removing Seat Covers.....	6
7. Installing the seat heater elements.....	7
8. Installing the wire harness and switch.....	8
9. Installing back the car seats.....	9
10. Final Testing.....	10
11. Electrical Diagrams.....	11
12. Tips and Tricks.....	12
13. Troubleshooting.....	13
14. Limited Warranty.....	14

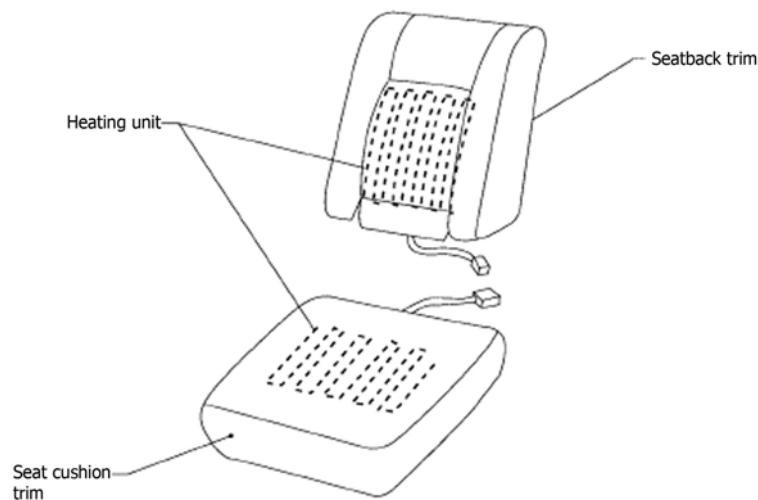

Figure 2 : Seat Heater Installation Locations

Disclaimer

Heizgerat Setzt™ seat heaters are recommended to be installed by experienced installers only.

Only use the parts and components supplied in the installation kit for the **Heizgerat Setzt™** seat heater installation. The supplied components are carefully tuned and adjusted for optimal performance. Foreign parts may lead to changes in current flow and other problems thus resulting in potential damage or functionality of the product. The heating temperature is varying depending on the structure of the seat-cover material and the current accessory load for the vehicle. Please keep in mind that thicker seat covers will result in greater loss of heat.

After the installation of the wire harness of the **Heizgerat Setzt™** seat heater it must be assured that when adjusting seat motion there will be no obstruction to the cables. A moving seat can cause interference and damage to the seat heater harness that is no longer protected by the limited warranty. The installation of the heating pads must be free of creases and wrinkles. Always consult the vehicles wiring diagram when unsure about individual wire/power source identification.

The side to side width of the heating elements must not be altered (cutting not permitted). Only cutting of the bottom of the seat heater element (opposite end of the wired end of the element) is allowed. To do this, please follow the instructions in the corresponding segment of this manual. Do not place any heavy, sharp or pointed objects on the seats with **Heizgerat Setzt™** seat heaters installed on it. Any fluids spilled on the seats may destroy the **Heizgerat Setzt™** seat heater and may cause damage to the vehicle. Never operate the seat heater while the seats are wet or soaked with fluid.

Do not keep insulating material (sheets, covers, coats, combustible materials) on the seats while the seat heater is operating. Do not place heat sensitive objects on the seats while the seat heater is running. To protect damage and discharge of the battery, avoid seat heater operation for extensive time periods without a running engine.

The installation instructions must be followed with utmost diligence by trained and properly qualified specialists as failures to comply (or mistakes during the installation phase) may cause damage to the system, the vehicle, and may potentially impose harm to drivers and/or passengers.

If you connect the seat heating system directly to the battery, it will be possible to run the seat heater without running the engine. Calculating a power consumption of about 70 watts per seat this would strain the battery considerably if left with the engine off.

Proper installation and repair procedures are vital to the reliable operation of all seat heaters as well as the personal safety of those performing the installation. Standard safety procedures and precautions (including use of safety goggles and proper tools and equipment) should be followed at all times to eliminate the possibility of personal injury or improper installation which could damage the vehicle or compromise its safety.

By installing the **Heizgerat Setzt™** seat heaters, you agree that **Heizgerat Setzt™** and its distributors or resellers are not responsible for fire and damage, or injury to the occupants of the vehicle that has the product installed on it. For more details you may read page 14 of this manual.

Package Contents

Components list supplied with the Heizgerat Setzt™ Seat Heater Kits

Qty.	Description of part
1	2-wired Seat Heater Element (top cushion)
1	4-wired Seat Heater Element (bottom cushion)
1	Temperature Sensor (located in 4-wired seat heater element)
1	Wire harness with integrated fuse holder
1	10 amp fuse
1	Round dual temperature switch (2 color illuminated)
1	Owners Instruction Manual
1	Control Module
1	Two year manufacturer warranty

Optional professional installer's kit available

Qty.	Description of part
4	Tap connectors
2	Grounding Screws
1	Large fusetap
1	Large fusetap insulated connector
1	Mini fusetap
1	Mini fusetape insulated connector
1	Large 10 amp fuse
1	Mini 10 amp fuse
1	Hog ring pliers
10	Zip ties
1	Electrical Tape
1	Hog ring strip

Optional installers accessories available

Qty.	Description of part
6	Hollow punch set
1	Wire crimper
1	Multimeter
6	Wire connectors

Optional accessories and installer kits are not required for most applications but are commonly used by professional installers worldwide.

Removing Car Seats

Before removing the front seats from the vehicle, raise the seat cushion to its maximum height for easy access to the seat fastener bolts.

Airbag Warning Light

In today's modern vehicles, there are highly sophisticated airbags on the vehicle seats. To avoid getting The Airbag Warning Light follow the procedures listed below... This procedure may or may not work on your vehicle, please contact your manufacturer for proper instructions.

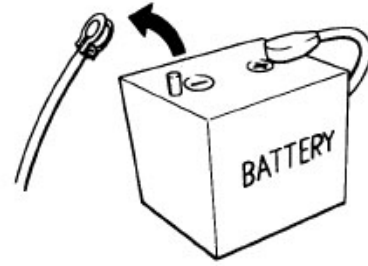

Figure 3 : Always remove negative wire.

1. Turn off the car and leave the key in the ignition in the off position.
2. Disconnect the negative terminal of the battery (**figure 3**) and isolate it with a rag, etc. so that it doesn't reconnect itself on accident. You must wait at least 5 minutes before continuing on the next step.
3. Remove the seats, disconnect the airbag, seatbelt, power seat connectors, etc. Do not turn back on the ignition at any time while the seats are out and the airbag/seatbelt connectors are disconnected!
4. Once you have the seats bolted back into the car and the airbag/seatbelt connectors reconnected, Be sure that the key is in the ignition (but not turned on), and then reconnect the negative terminal of the battery.

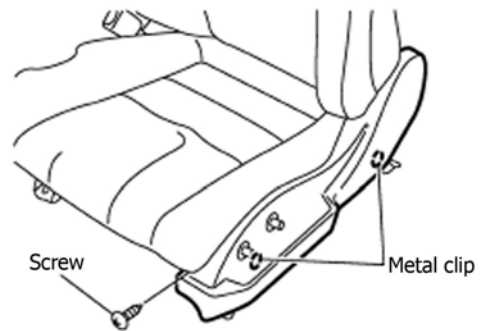

Figure 4 : Remove panels and knobs.

Removal of the vehicles seat

Before removal of the vehicles seat, follow the manufacturer's recommendations in this procedure. To ease the removal of the vehicles seat, remove the headrest, seat belts, and anything else that will hinder the removal of the seat. Slide the seat to access the four mounting fasteners that hold the seat down to the frame of the vehicle on each corner of the seat. If required remove trim panels or covers to access the seat-mounting fasteners. When removing the seat-mounting fasteners, replace one-time or damaged fasteners because improper reinstallation may cause vehicle seat to fall out in a collision.

Disconnect all electrical connector plugs if required, mark them for reinstallation. Remove the seat assembly from the vehicle, carefully as the sharp bottom may cause personal injury or damage the vehicles interior. Position the removed vehicle seats on a proper work bench or table; beware of sharp metal edges under the chair. Remove all side covers, moldings, outer parts, and accessories to make the removal of the seat cushions easier. Disassemble the seats lower pad and backrest and remove the seat frame by removing the attachment screws.

Vehicle Seat Removal Checklist

- Prevent damage to the seat, adjacent parts, and seat track adjuster assembly.
- Protect the seat assembly and adjacent parts from damage during removal, storage, and installation.
- Torque mounting fasteners to the vehicle maker's recommendations.

Removing Seat Covers

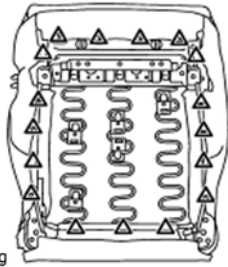

△: Hog ring

Figure 5 : Remove all hog rings.

When removing the seat covers from the cushions, remove all upholstery clamps that are holding the seat covers in place using appropriate pliers. Wear safety goggles during the procedure, and beware of very sharp rusted hog rings.

To begin removing the seat covers from the vehicles seat, you must remove all circular metal rings called hog rings. Start from the back seats, they are generally much easier, and will give you a general idea of the task that you have just taken on. Turn one of the back seat

cushions over and you will be able to access the hog rings that attach the outer skirting of the cloth seats. Now begin by clipping the factory hog rings off with a plier.

Once you have finished clipping the hog rings off the outer edge of the foam cushion, lift up the edge of the seat cover material and begin to clip the hog rings that secure the center inserts of the seat covers (**figure 5**). A bent needle nose plier or side cutting plier can be used to remove hog rings.

Remove the covers off both the vehicles seat cushions (**figure 6**). Remove and dispose of all upholstery clips as re-using them will weaken the strength of the hog rings. Unhook all obstructions using a suitable screwdriver (+ Phillips) and socket wrench. You may choose to use small zip ties as replacement for the hog rings if you cannot locate them in your local hardware store.

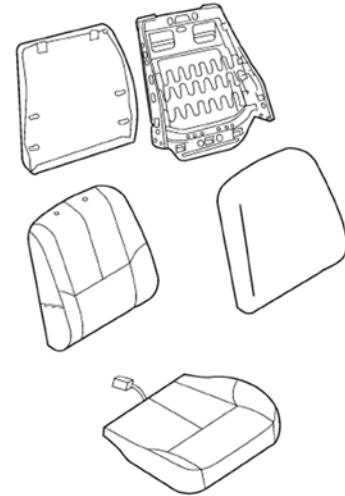

Figure 6 : Typical Seat Cover Setup

Clean the top of the foam of loose particles as later the adhesive side of the seat heater elements will be taped to the cushions foam. If the foam on the cushions is damaged in anyway, you may simply patch up with pieces of foam to cover up the damaged areas and use appropriate tape (duct tape) and glue to keep the foam in place.

If driver's seat is equipped with an armrest, it must be removed prior to the removal of the top cushions seat cover. To prevent damage to the headrest sockets, avoid removing the entire top cushion cover. Remove only enough until you have sufficient working space to install the elements.

Important Notes:

- Remember all locations of where the hog rings were removed, the hog rings should be reinstalled in the same place that they were taken out from. You may also look at the holes on the end of the seat covers (where the hog rings were located) or seat cushion to make it easier to find.
- The back cushion may have two headrest mounting brackets. You don't have to remove these because you can actually leave them on when you attach the seat heater elements to the cushion. This will avoid the chance of breaking them in the process.

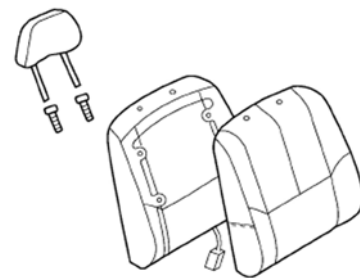

Figure 7 : Its not necessary to remove the head rest.

Installing the Heizgerat Setzt™ Seat Heater Elements

Measure the width of the center seat segments (lower part and back rest) between the horizontal seams (width to width). The width must be at least 10-11" and it is very important that the heating elements do not contact the side seams. You may trim off the excess cloth located on the outer edge of the heating elements using a scissor for fitment purposes only. Ensure that you do not cut past the adhesive tape as doing so may cause the heating element to malfunction. Please note that warranty is voided, once the seat heater elements are altered in any way.

It is recommended the temperature sensor on the 4-wired seat heater element not be installed in a recessed area. If the sensor must be placed in a recess, move sensor to make sure the adhesive tape will still be glued to a level surface. It may be necessary to remove small parts of the foam with a sharp knife in order to make sure that the wires will not be noticed in the finished seat. Never cut or fold the heating element near the temperature sensor, as doing so will cause the seat heater to completely stop working. The four wire element **MUST** be installed on the bottom cushion.

Installing Heizgerat Setzt™ seat heaters on cushions with channels

If you wish to keep the channel shape of the cushion it is possible with Heizgerat Setzt™ seat heaters. First, mark the middle of a channel horizontal (width to width) to the seat heater on the cushion. Using the diagram on the right (**figure 8**), you can cut 1-5 holes with a diameter of about 1 inch out of the heating element utilizing the cutting stencil. Holes should be only cut where the hog rings are located, the hog rings will be replaced by the provided plastic zip ties. This is due to the fact that the hog rings will conduct electricity with the exposed elements resulting in lost heat. You may cut the heating element to a desired length and isolate the edge using the provided adhesive tape. This is only necessary if the heating element is too long. Always cut the bottom end of the heater element which is opposite of the wired end. Remove the adhesive backing and thoroughly glue the element to the top of the foam.

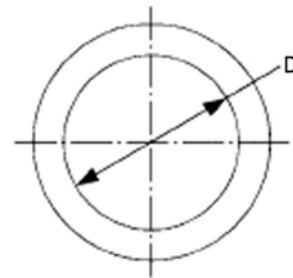

Figure 8 : D=Diameter must not exceed 1".

Important Notes:

- Never cut holes in areas covered with adhesive tape! Use that as a guideline!
- Areas covered with adhesive tape have to be glued on a leveled surface only.
- Never cut in areas near to the temperature sensor, the sensor is located near where the 4-wired heater element meets the wire.
- The 4-wired heater element **must** be installed on the bottom cushion only
- The adhesive side is always taped to the cushion foam.
- Cutting holes into the seat heater element is allowed to keep the shape of the channels, please note that once the holes are created the horizontal (width to width) area will no longer provide heat.
- Always replace hog rings with the provided plastic zip ties, as metallic hog rings can conduct electricity resulting in lost heat and electricity.

Tips and Tricks:

- Use a hollow punch to make the shape of the hole (you can also use a marker), once the shape is identified, or you may fold the element in half and use a scissor to cut a triangular hole.

Installing the wire harness and the 2 color illuminated switch

Positive power connection:

The positive (red wire) can be connected to either the ignition positive power (accessory), fuse box (**figure 8**), or from the 12 volt socket connection. Never connect the positive wire directly to the battery.

Negative power connection:

Using a conductive grounding screw, securely attach the ground eyelet on the black ground wire from the seat heater harness to the negative body of the vehicle chassis. Improper grounding will cause the seat heater to not function. Do not share the negative ground if you are installing multiple units.

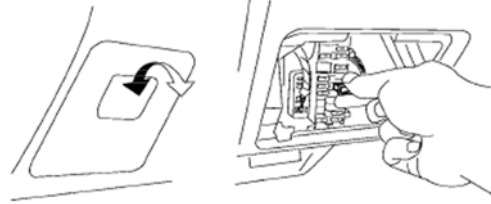

Figure 9 : Getting the power from the fuse box.

Precautions:

Disconnect the battery prior to any activities with the vehicle wiring system. Mount the control Module and fuse holder in an inconspicuous area so that moisture from the carpet will not affect operation. Be sure that the installed control module and fuse holder do not interfere with the motion of the seat or cause any strain on the harness when the seat is moved. Be sure that there is enough room to mount the fuse holder with the connector attached. Attach the seat heater wiring harness with the cable ties provided, and assure that all necessary movement of the vehicle seat is still possible. Assure that all connectors and plugs are re-connected and not loose, check for proper function.

Installation of the 2 color dual temperature round seat heater switch

Select a convenient or easy to access location (**figure 10**) for the switch and assure that the location provides ample space to mount the round switch and the switch bracket. Mark the location for mounting the switch and drill an approximate 20mm hole for mounting of the switch. Assure that the mounting hole is not too small (pressure from pressing the switch may cause potential malfunctions) nor too large of an opening. (improper seating of the switch will cause poor or loose fit and the switch may fall through the hole). Always install the seat heater switch in a location easily accessible by occupants of the vehicle. The dual illuminated rocker switches has multi colors to represent the different temperature settings available. The green light represents low heat and red light represents high heat. A uni-bit or step bit can be used to drill the perfect hole.



Figure 10 : Typical Switch Mounting Location.

Routing of the wiring harness

Assure that the location and positioning of the wire harness for the seat heater does not interfere with seat motions. Any chafing, rubbing, stretching and/or any stress on the harness may result in damage to the seat heater as well as partial or total failure of seat motion. Use the provided cable ties to attach the wiring harness to non moving parts of the car.

Route the wire harness with the two white prong connectors under the carpet to reach the individual seat. Allow for as much wire length as possible to assure unrestricted seat movement. Run the wire harness with the red positive wires and black ground wires to the nearest adequate source.

Installing back the car seats

Reassembly is basically the reverse of the disassembly in pages 5 and 6 of the installation manual. Make sure there are no twists or kinks in the front seat belts and ensure that they are functioning properly. To prevent wrinkles in the seat-back cover, stretch the material evenly over the cushions pad. Remember that vehicles with Airbags must follow the instructions below, failing to do so may require a visit to your local dealership to reset the Airbag light.

Airbag Warning Light

In today's modern vehicles, there are highly sophisticated airbags on the vehicle seat. To avoid getting Airbag Warning Light follow the procedures listed below... This procedure may or may not work on your vehicle, please contact your manufacture for proper instructions.

- 1 Turn off the car and leave the key in the ignition in the off position.
- 2 Disconnect the negative terminal of the battery and isolate it with a rag, etc. so that it doesn't reconnect itself on accident. You must wait at least 5 minutes before continuing on the next step.
- 3 Remove the seats, disconnect the airbag, seatbelt, power seat connectors, etc.
NOTE: Do not turn back on the ignition at any time while the seats are out and the airbag / seatbelt connectors are disconnected!
- 4 Once you have the seats bolted back into the car and the airbag/seatbelt connectors reconnected, Be sure that the key is in the ignition (but not turned on), and then reconnect the negative terminal of the battery.

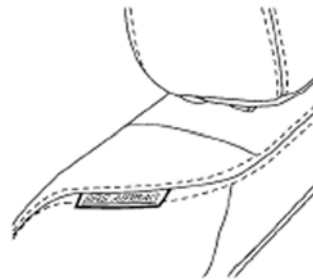

Figure 11 : Check for SRS Airbags on Seats.

After the seats are installed back into the vehicle, the seats should appear to be look original and never touched. That is the great benefit of purchasing **Heizgerat Setzt™** seat heater systems.

Installation of the vehicles seat

Before installation of the seats, follow the manufacturer's recommendations in this procedure. To ease the installation of the vehicles seat, slide the seat to access the four mounting fasteners that hold the seat down to the frame of the vehicle.

When installing the seat-mounting fasteners, replace one-time or damaged fasteners because improper installation may cause seat to fall out in a collision. Always torque the mounting fasteners to the vehicle maker's recommendations

Re-install trim panels or covers to hide the seat-mounting fasteners. (**figure 12**) You may apply multi purpose grease to the moving portion of the seat track. Check operation of the recline and slide up/down adjusters.

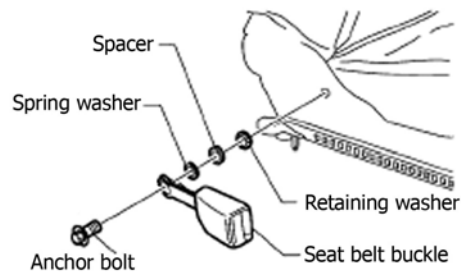

Figure 12 : Seat Belt re-installation.

Install back headrest to the top cushion of the seats.

Important Notes:

- Ensure there are no creases or kinks on the seat covers, they should look as they were never removed.

Final Testing

Testing the seat heaters

Seat Heater performance will really depend on the vehicles current accessory load and condition of the vehicles battery and charging system. These factors will greatly affect the time it takes to warm up the seat heaters.

The average time it takes to warm up is anywhere from 5 mins to 10 mins. Under the HIGH settings, the seat heater elements can reach temperatures from 103 degrees to 107 degrees (plus or minus 5 degrees) whereas the LOW settings can reach temperatures from 97 degrees to 101 degrees (plus or minus 5 degrees). Please ensure that your vehicles battery can support the additional load of 12 volts / 4.7 amp / 60W heat, that is the minimum requirement for our seat heater systems. We have never come across a vehicle that didn't fit this requirement so you can rest assured that there will be no problems during the installation for your vehicle.



Figure 13 : Testing the Elements.

Testing the vehicles seat

While sitting on the installed vehicles seat, rock the chair back and forth to see the seat mounting fasteners are tightly in place. Ask an assistance to look at the seat heater wiring harness and adjust the seat front and back to see if the wires maybe obstructed by the moving parts of the seat.

To ensure a quality test, please check the following

- The vehicle must be operating with the engine running.
- The vehicle seat where the seat heater was installed must be occupied.
- Your battery and charging system is in good condition, providing enough current for the seat heaters to function.
- Your negative black wire is properly grounded.
- Test all off/low/high functions of the 2 color illuminated switch.

Important Notes:

- 2 colored illuminated switch specifications
LOW = GREEN, OFF = NO LIGHT, HIGH = RED
- Seat Heater Elements should be connected directly to the battery prior to contacting us for warranty related replacements. The seat heater elements will produce heat in 5-10 minutes if your vehicles engine is running.
- You can test the negative wire by using an Electrical Test Light. By connecting the test light to a good 12 volt power source, there should be light when you tap the tester to negative wire of the wiring harness.
- You can install the seat heaters using a 12 volt adapter or use the OEM seat heater switches with our kits. Our installers regularly install our seat heaters on brand new vehicles using the original seat heater switches. This is only possible if you are electrically inclined, and know what you are doing. Please note that we do not offer technical support if you plan to do this, and warranty is immediately voided at the same time. We highly recommend you to get the wiring schematics before any modifications are made.

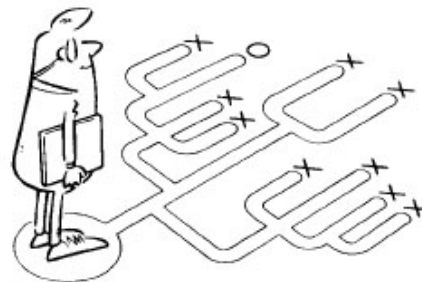
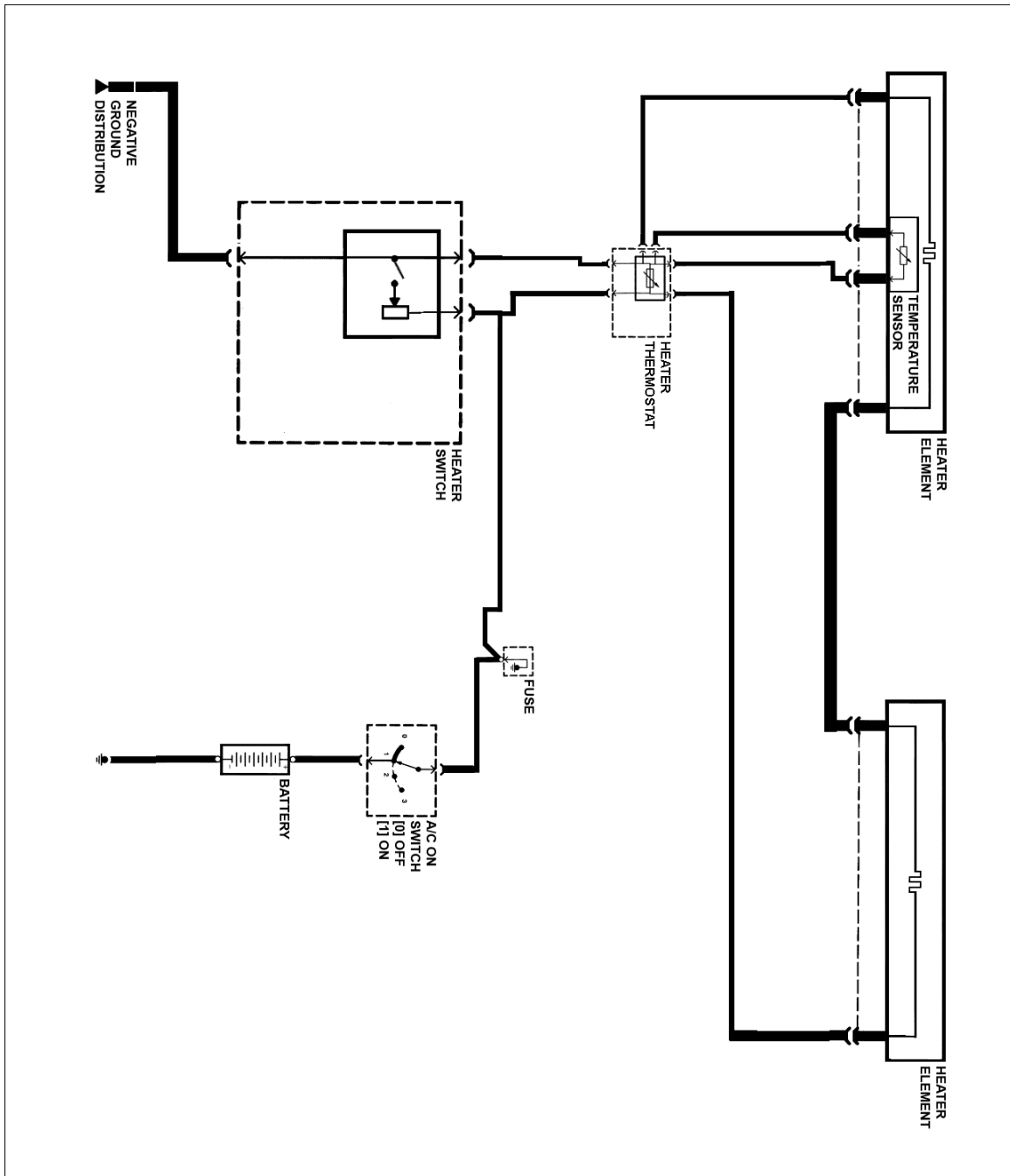

Figure 14 : Troubleshooting Problems.

Electrical Diagrams



Last updated September 2000

Tips and Tricks

Before Starting Installation

Automotive electrical experience is beneficial for this installation. Familiarize yourself with the installation instructions and seat heater system components, prior to install the system. Invest money in a hog ring plier, or professional installation kit as it will make the job a lot more easier.

Removal of Negative Battery Cable

Always disconnect the negative battery cable before install seat heater system components as a safety precaution. If your vehicle is equipped with an anti-theft security code, please ensure that you write it down before installation of the seat heaters.

Installation of the wiring harness

Be sure to install the wiring harness so that they are not pinched or interfere with moving parts of the vehicle seat. After installation of our products, the only thing visible should be the 20mm seat heater switch. This is one of the great benefits for purchasing **Heizgerat Setzt** Seat Heaters. Properly installed, our seat heaters will function better than a lot of the OEM seat heaters found in today's new vehicles. Our seat heaters are installed daily on brand new vehicles at dealerships across North America.

Removal:
Remove by bending up with flat-bladed screwdrivers or clip remover.

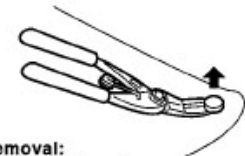

Removal:
Remove with a clip remover.

Figure 15 : Remove common clips.

Mounting the vehicle's seat back to the car

Put on thick gloves to protect your hands from the sharp under carriage of the vehicles seat. Ensure the seat moves freely prior to the installation. Ensure the seat is securely bolted to the chassis of the vehicle. Avoid rattling noises caused by improper installation. Always ensure the seats function the same prior to removal.

Velcro Seat Covers

In a lot of today's newer vehicles, velcro is used to hold down the seat covers to the cushion. It is not necessary for you to cut a hole in the elements to allow the velcro to connect. You may opt to sew on velcro strips to our seat heater elements. This way the Velcro system is still connecting and there are no holes to be cut. Velcro can be bought from your local hardware store or supermarket. It is not recommended to sew on the taped areas of the seat heater elements, use them as a guideline when making modifications to the element pad. If you do not have new replacement hog rings, you may use small zip ties as a substitute.

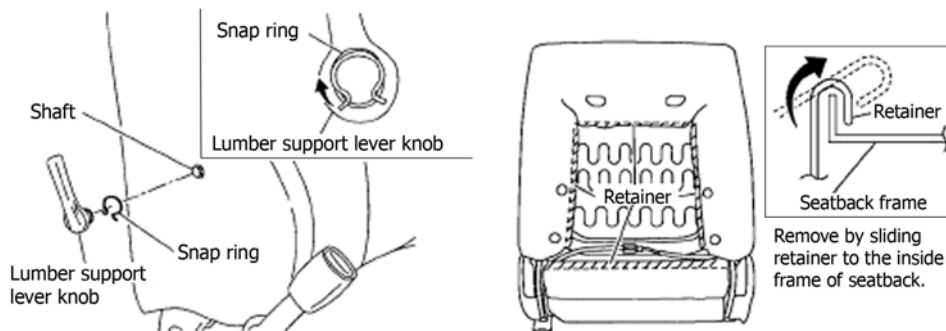

Figure 16 : Typical Seat Design.

Troubleshooting

Simple tests

In tracking down the possible causes for a non-functioning seat heater, the thing to keep in mind is to “Keep it simple.”

- Inspect the fuses first.
- The vehicle must be operating with the engine running.
- Check the electrical plug under the seat where the seat heater elements plug into the main wiring harness.
- Check the plug that connects the seat heater element to the seat bottom. If this is unplugged, the seat will not work.
- Our seat heater elements have a pressure switch located on the 4-wired heater element, therefore the seat heater will not activate if the seat is not occupied.
- Make sure all plugs and connectors are free of corrosion and dirt and securely in place.
- Test all off/low/high functions of the 2 color illuminated switch.
- Ensure that the negative black wire is properly grounded.

Testing the wiring harness

Slide the seat as far back or forward as it will allow easy access to the wiring harness's connectors under the seat.

Unplug the seat connectors and verify with the ignition key in the “on” position that there is power at the plug. If so, the problem can be assumed to be the seat heater elements and not a problem with the electrical power delivery. If there is no power at the seat heaters connector's plug, the switch or wiring harness may be the cause of the malfunction. In some rare cases, the negative ground maybe not be properly grounded to the negative chassis of the vehicle. In most common cases, the fuse has blown, inadequate power source, or a defective switch.

With the seat connectors now unplugged, locate and pull out the white seat heaters connector's plug that connects the seatback to the lower cushion area. With a continuity tester or volt-ohm meter, verify continuity in the seatback elements. To verify the functionality of the seat heater elements, you may connect the positive and negative of the elements wiring directly to the positive and negative of the battery. If the seat heater elements are producing heat, the wiring harness is the suspected cause of the malfunction.

Inspect the seat heater electrical parts for these conditions using this checklist:

- Blown fuse
- Defective switch
- Defective wiring harness
- Loose or corroded grounds or connectors
- Damaged wiring or connectors
- Corrosion on terminal pins
- Defective control module
- Defective seat heater elements
- Improper positive source

Heizgerat Setzt boasts a warranty defective rate of 1 per 5,000 seat heaters manufactured. Ninety-Five percent of seat heaters returned work perfectly, please note that you will be charged for filing false warranty claims. Modified or altered parts are no longer covered by the warranty, you may opt to purchase the replacement parts directly from the distributor. By installing the seat heaters properly the first time, will save everyone a lot of time, hassle, and money.

Limited Warranty

Heizgerat Setzt™ warrants to the original retail purchaser of this product that should this product or any part thereof, under normal use and conditions, be proven to have defective material or workmanship within 24 months or 30,000 miles of the original purchase, such defect(s) will be repaired or replaced (at the company's option) without charge for the parts. This warranty does not apply to batteries or normal wear and tear associated with the product.

Not covered in the warranty are damages resulting from:

- Improper handling of components and seat heater systems
- Failure to follow installation instructions
- Unauthorized installation
- Installations by non qualified or certified installers to do the installation
- Overused or water damaged
- Modified or altered seat heater components
- Overheating or fire damage

The warranty covers only parts and materials. Subsequent damage of any kind, even as a result of damage or flawed components is not covered by this limited warranty. The vendor's warranty procedures must be followed to become eligible for a warranty claim. The vendor reserves the discretionary right to determine whether the defective unit will be repaired, replaced entirely or whether only components will be sent to correct the defects.

Only such warranty claims can be processed and honored, where buyer provides the vendor at the time of the claim with the following documents.

- Proof of purchase or invoice
- Proof of payment
- Proof of installation by authorized and qualified installer experienced in this product
- Both labels on the seat heater system's heater pads must contain vehicle data like year, make, and model of the car as well as the date of the seat heater system installation

This warranty does not cover costs incurred for the removal or reinstallation of the product, related components, or damage to the vehicle's electrical system or components. Some states do not allow limitations on how long an implied warranty lasts or the exclusion or limitation of incidental or consequential damage so the above limitations or exclusions may not apply to you. This warranty gives you specific legal rights and you may also have other rights which vary from state to state. By installing our seat heaters you agree to the terms and conditions listed above.

HEIZGERAT SETZT LIMITED WARRANTY CARD			
FIRST NAME:	LAST NAME:	INITIALS:	
DATE OF PURCHASE: / /	INSTALLED BY:		
ADDRESS:	CITY:	STATE:	
ZIPCODE:	COUNTRY:		
VEHICLES INSTALLED ON			
MAKE:	MODEL:	YEAR:	MILEAGE:
WOULD YOU LIKE MORE INFORMATION ON OUR PRODUCTS?			

MAIL TO DISTRIBUTOR: HEIZGERAT SETZT WARRANTY, 250 "H" STREET #565, BLAINE, WA 98230, UNITED STATES